



Established Since 2006



Company Profile

About Us

PT Wellracom Industri Komputindo is a Leading Company that engaged as a Distibutor Industrial PC, Industrial Automation and Industrial Process for Industrial Manufacturing Company since 2006

Wellracom will establish cooperation with Integrator companies which are service or device provider partners in the form of product end users. In fact, we are also building a business with buyers who need industrial PC products.



**Established
Since 2006**



**Vast experience in
Industrial PC and
Automation Solution**

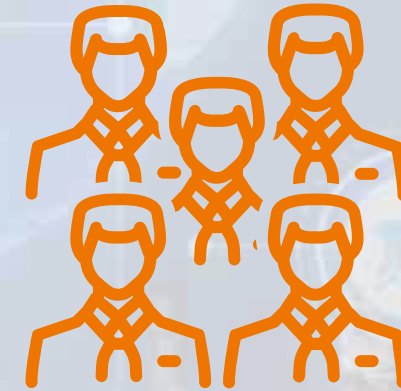

**50+ Employees &
Dedicated team of
staffs**



**Headquarter at
Kuningan, Jakarta
and Office
Representative at
Surabaya**

**Sales & Services
Support Structure**

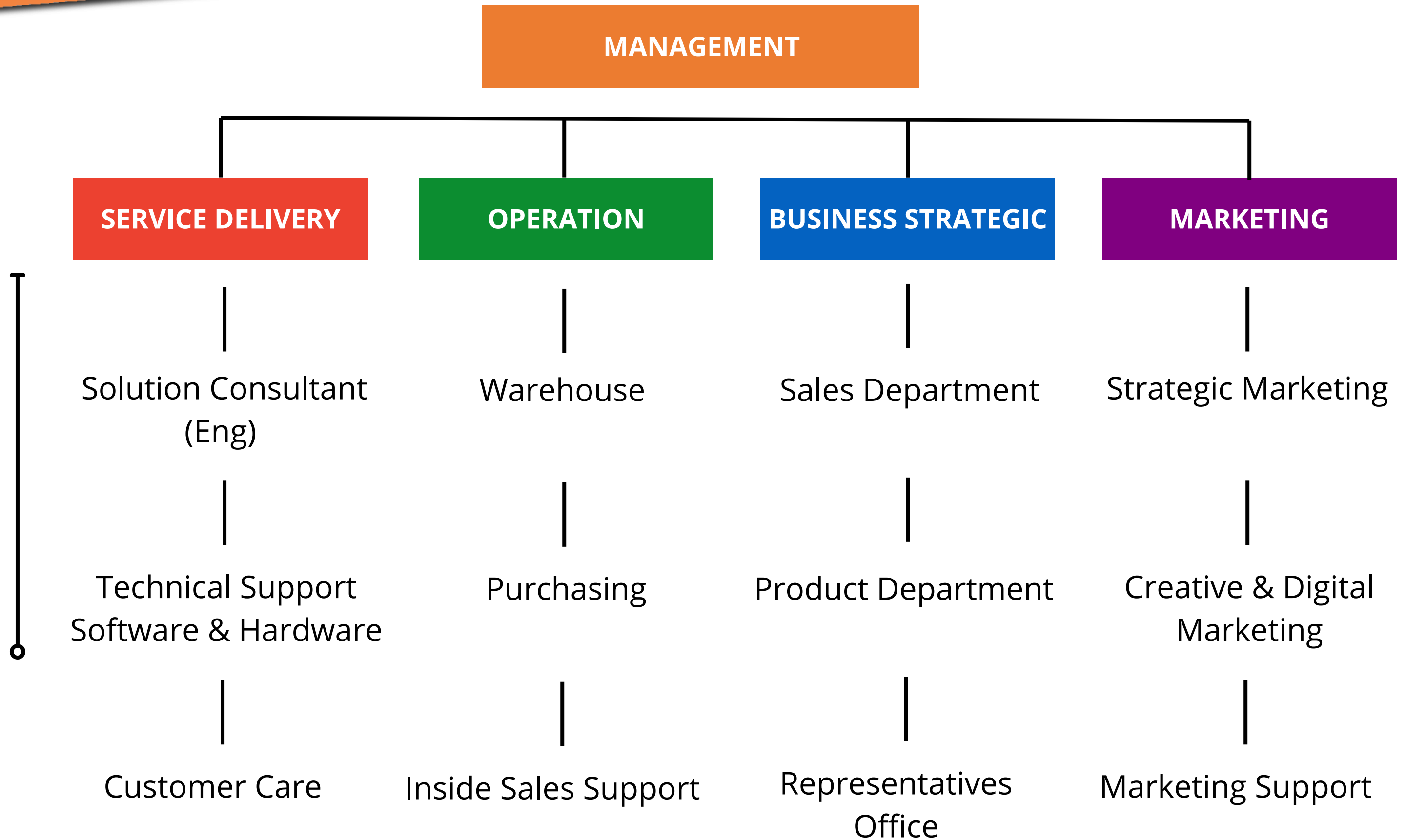



Wellracom Domestic Network & Representative Office

Jakarta :
Epincentrum Walk A707
Rasuna Epicentrum
Kuningan
Jl. HR Rasuna Said, Jakarta

Surabaya :
Jl. Bratang Binangun
83 Surabaya 60284

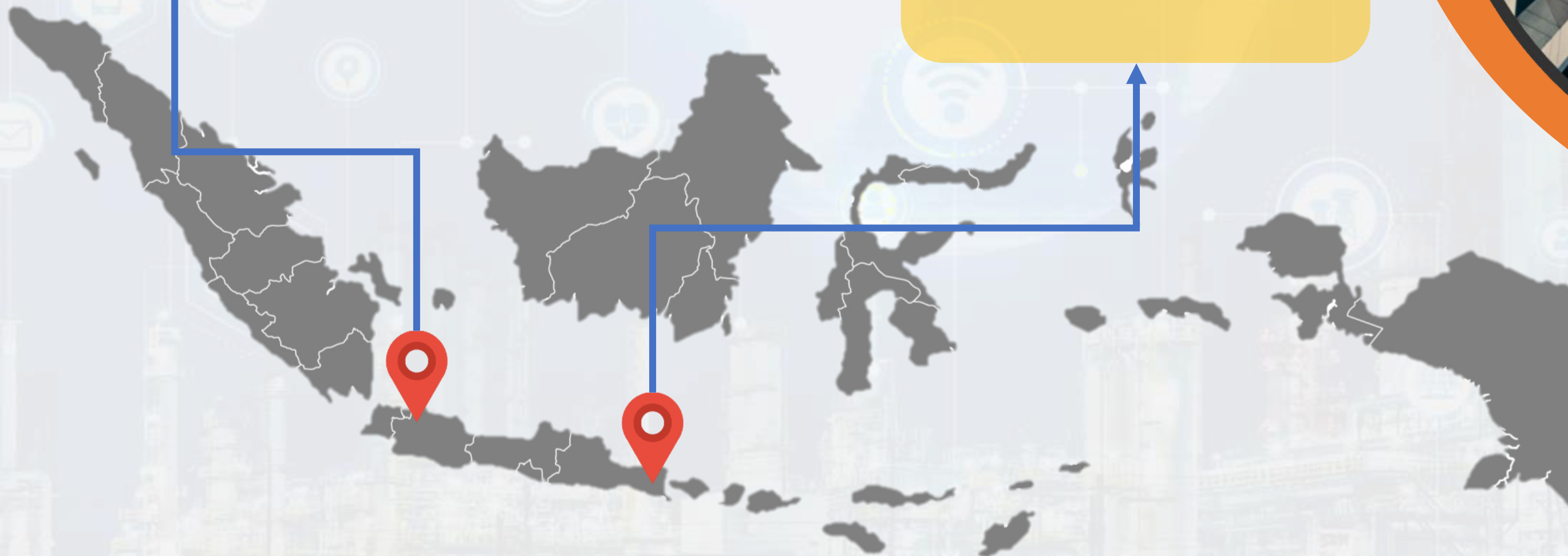



Industrial PC



**Automation
Solution**



**Business
Focus**



**Industrial
Process**

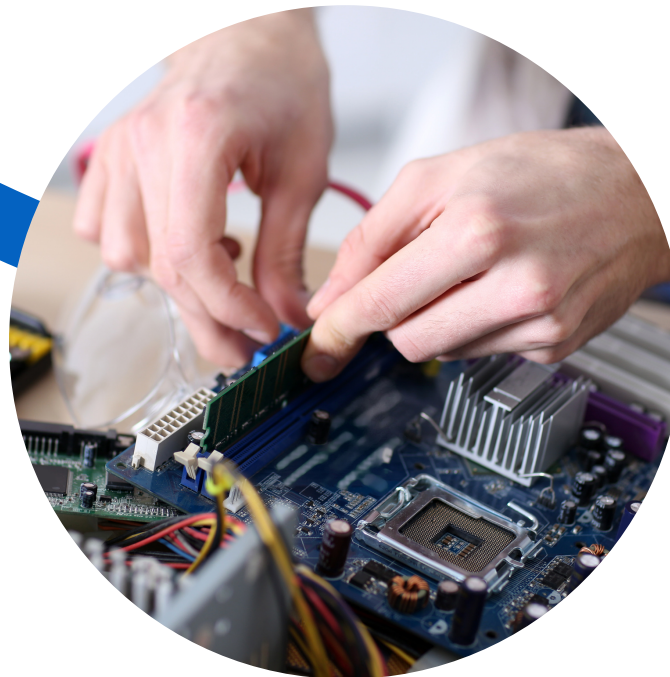

Service Center



Internet Of Things



PT Wellracom Industri Komputindo was established in 2006, we provide Industrial PC, Fanless Embedded PC, Remote IO, IOT Gateway and Automation Solution

Distributor Product:



- Industrial PC
- Fanless Embedded PC
- Industrial Panel PC
- AI Computing
- Industrial Server



- IIOT Controller
- Industrial Protocol gateway
- I/O Module
- Industrial Networking
- SCADA System



- Industrial Data Recorder
- PID Controller
- Thyristor Controller
- Sinyal Conditioning Module





SOLUTION PRODUCT



Utility Monitoring OEE



Gas Monitoring



Fire Alarm Monitoring



IOT & Remote Area



Monitoring TETRA radio



Provider



AXIOMTEK

Founded in 1990, Axiomtek is a leading design and manufacturing company in the industrial computer and embedded field.



Embedded System



Touch Panel System



Edge AI System



Network Communication Platform



Embedded System



Industrial PC



Fanless



Wide Temp.



IP40



Industrial Motherboard



Transportation PC



Fanless



Wide Temp.



EN50155



IP30



EN45545



Din Rail PC



Medical Grade



Fanless



TPM



UL60950-1



IPMI



4K Ultra HD



Isolation



Touch Panel System



**Fanless Touch Panel
PC & Monitor**



Fanless



Wide Temp.



IP65



AiRD



IP69K



**Transportation Touch Panel
PC & Monitor**



Fanless



Wide Temp.



EN50155



IP65



EN45545



M12
Connector



Medical Grade



Fanless



AiRD



Isolation



Low Power



Edge AI System



4K Ultra HD



IP67



Waterproof



Wide Temp.



Fanless

Features

- IP67-rated design for outdoor edge AI applications
- NVIDIA® Jetson Xavier™ NX with 384-core NVIDIA Volta™ GPU with 48 Tensor Cores
- High AI computing performance for GPU accelerated processing
- -30°C to +50°C operating temperature range
- 9 to 36 VDC wide range power input
- Features M12 lockable I/Os

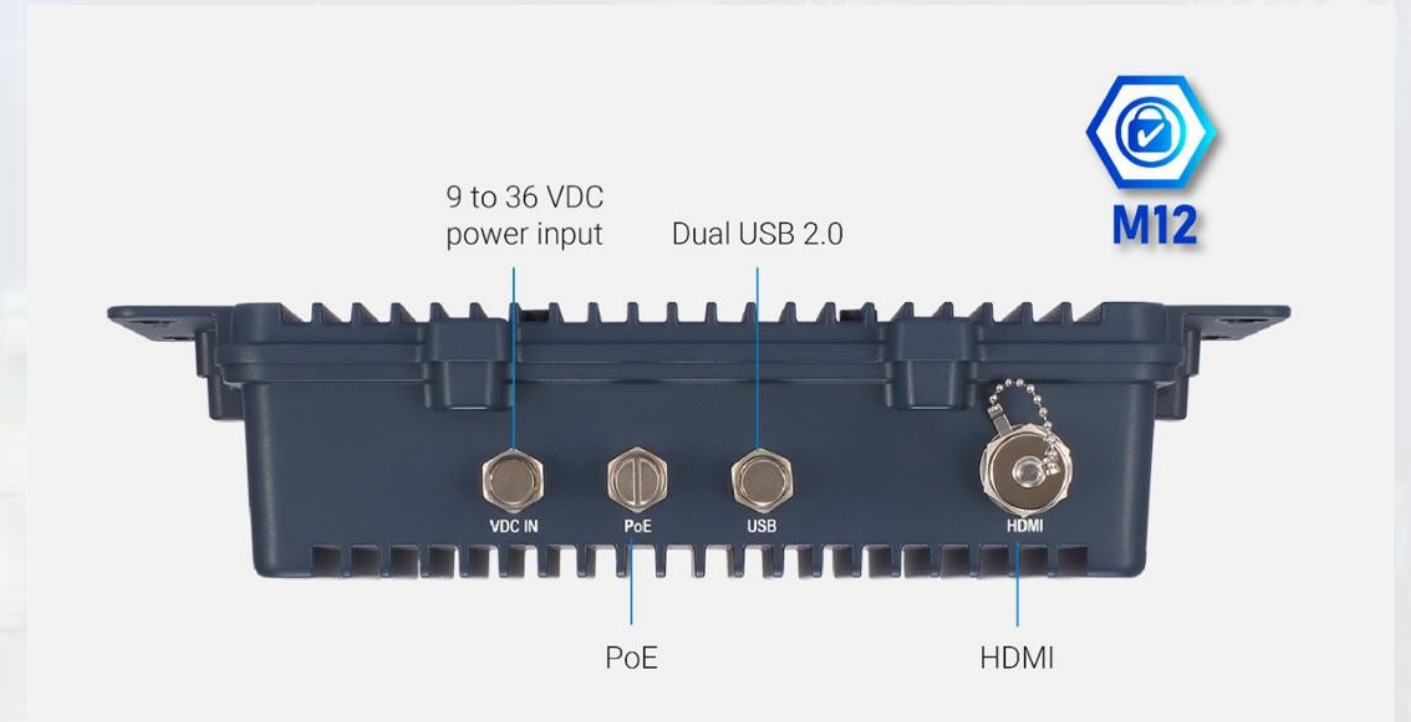



Network Communication Platform



Low Power



LAN Bypass



Wide Temp.



TPM



Fanless

Features

- Intel Atom® x6212RE/x6414RE processor (Elkhart Lake)
- DDR4-3200 SO-DIMM, up to 32GB
- 2 GbE LAN, 2 2.5GbE LAN, and 2 SFP
- Wide operating temperature from -40°C to +70°C
- Wide power input of 9 to 36V DC with dual power input
- Supports 5G with M.2 Key B 3042/3052
- Supports TPM 2.0
- Ideal for OT field site cybersecurity and secured edge

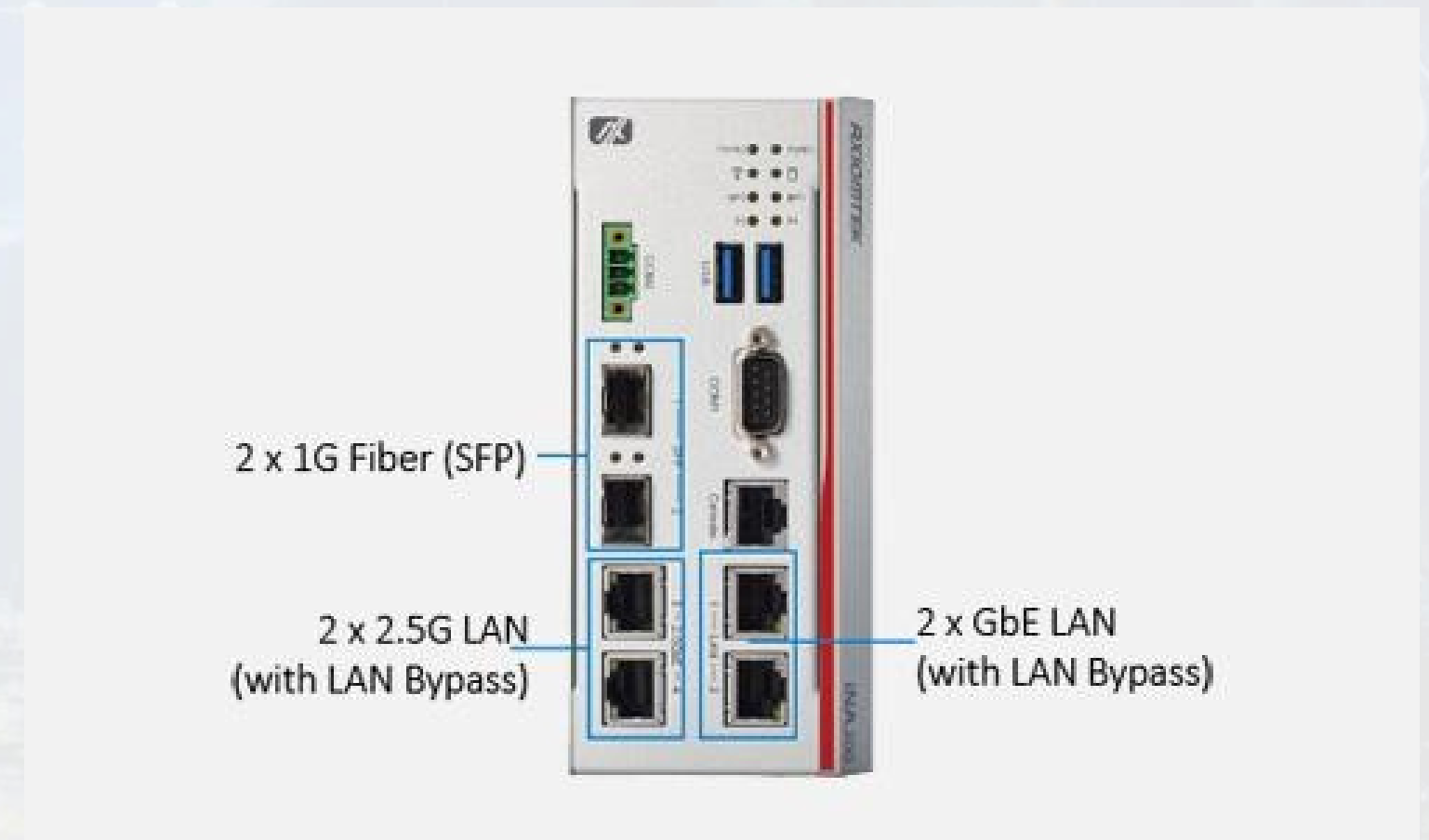



**ICP
DAS**

ICP DAS, established in 1993, focuses on innovation and improving the industrial automation technology. With the widespread of internet and the extension of household and entertainment, it becomes a trend to integrate data acquisition, industrial control, and communication as one complete system. The embedded-control system has also become the focal point of research and application



IIOT
Controller



Industrial
Communication



Remote IO



Industrial M2M
Wireless Solution



SCADA



IIOT Controller

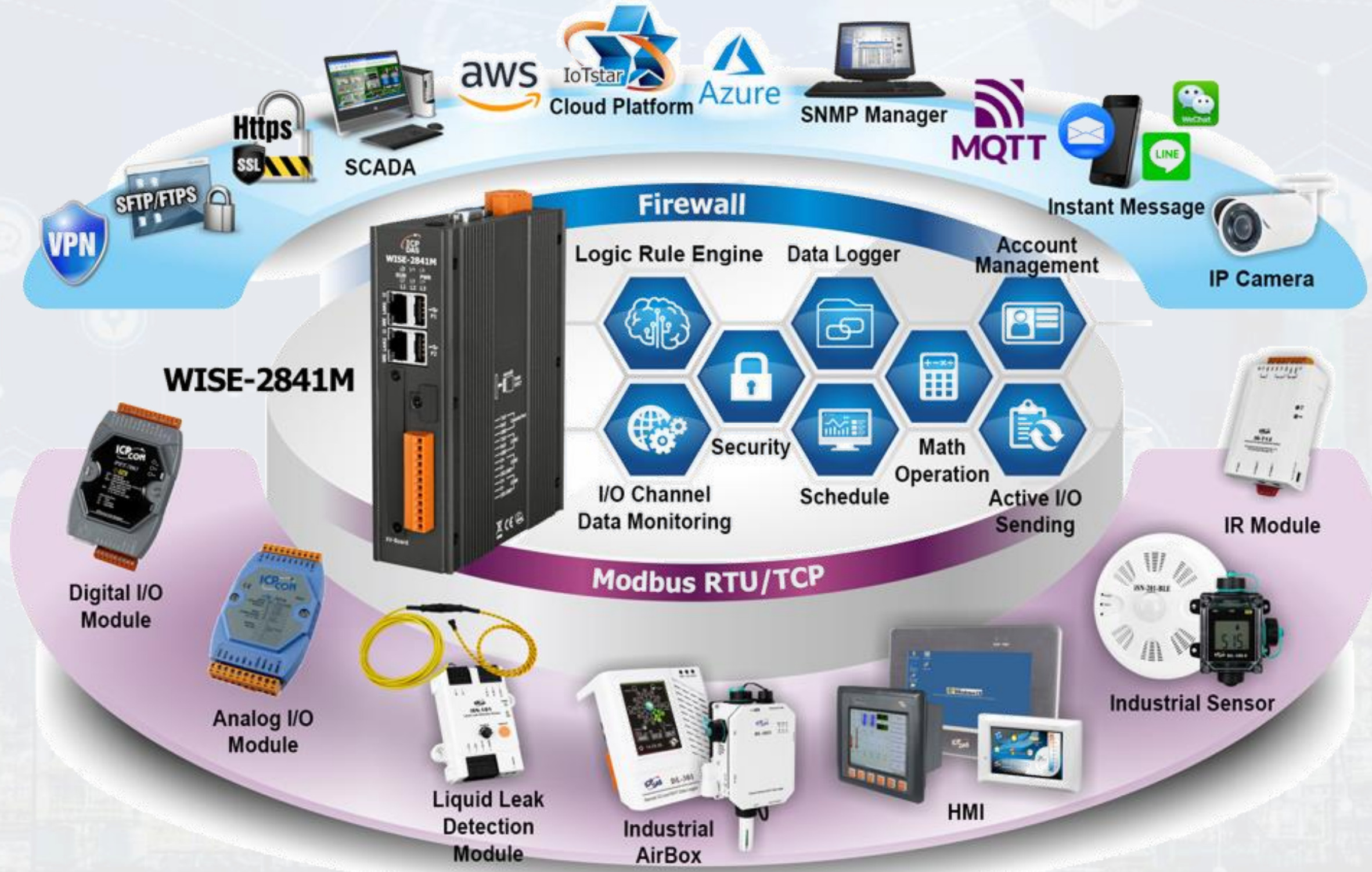



Industrial Communication

For connecting and exchanging data among various automation devices in industrial fields, ICP DAS provides a variety of different communication products to support widely used industrial communication protocols and interfaces.





Industrial Remote IO

Remote I/O Modules support a wide range of of field signals including current, voltage, thermistor, thermocouple, RTD, and strain gauge with many protocols and interfaces..



EtherNet/IP

PROFIBUS

PROFINET

Modbus

EtherCAT

CANopen

ASHRAE BACnet

DeviceNet

zigbee

WiFi



Industrial M2M Wireless Solution

Realizing the data acquisition, management and status monitoring by wireless network has become a promising approach in a vast range of industrial applications. Robust industrial wireless products supporting for ZigBee, Wi-Fi, 3G/4G/5G, Bluetooth, IR, LoRa, NB-IoT communication are offered.

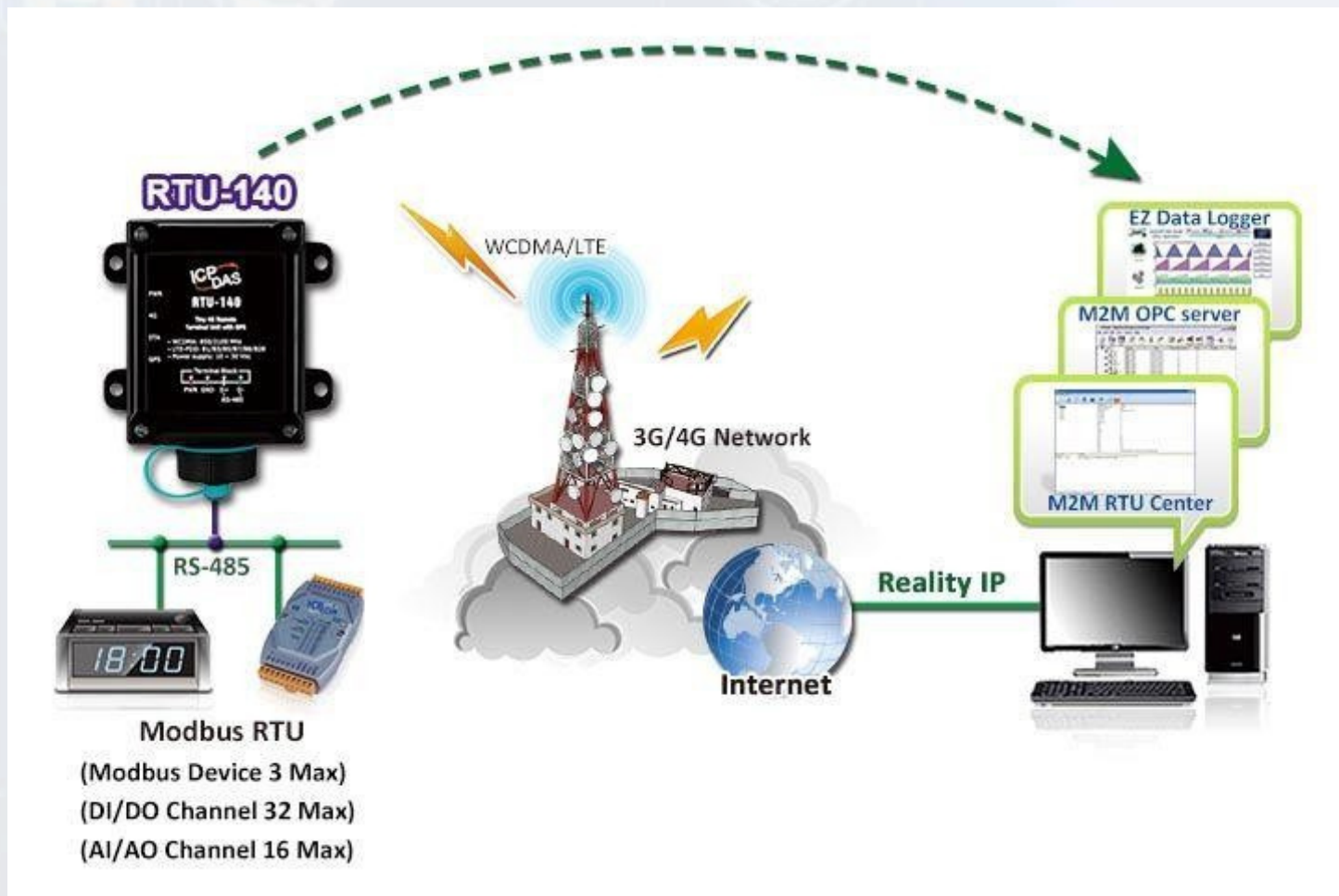



SCADA



AVEVA Edge is a comprehensive platform that includes all the tools you'll need to make SCADA and HMI applications that have real power behind them. The development environment allows you to develop once and deploy anywhere. AVEVA Edge supports all Windows runtime platforms (including 32 and 64 bit), ranging from Windows Embedded Compact, Windows Embedded Standard, Windows 8.1/10 and Windows Server Editions (Server 2012R2/2016/2019), along with built-in support for local or remote (web) based visualization.

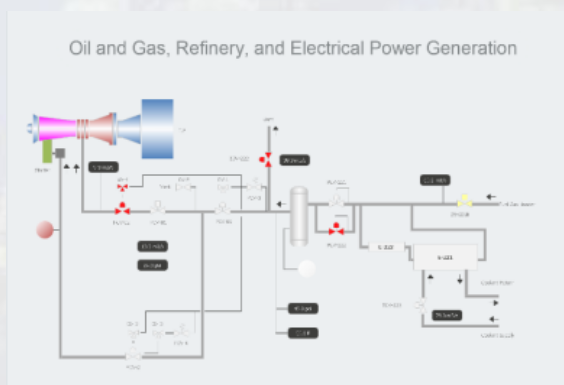
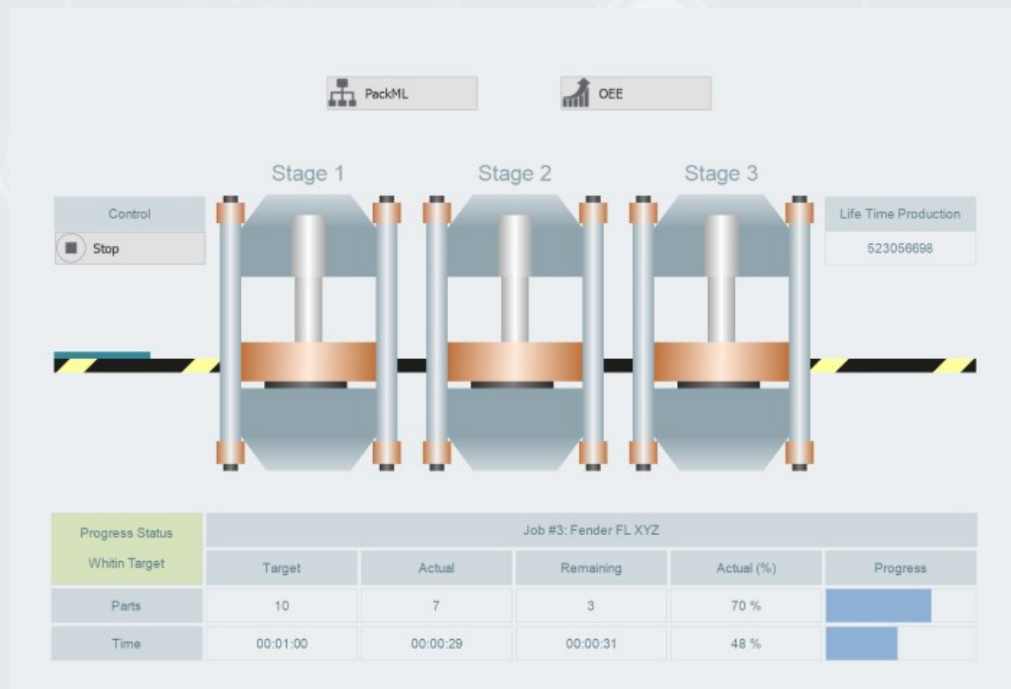

AVEVA™ Edge

Easy Step to Meet Your Satisfaction

ViewPAC

WinPAC

XPAC



Eurotherm

Eurotherm is a leading global supplier of control, measurement and data recording solutions and services to industrial and process customers



PID Controller



Power Controller

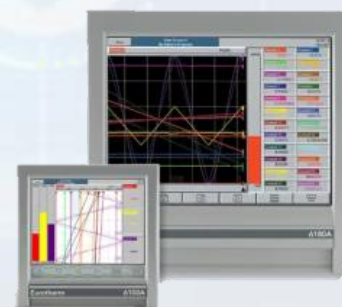

Paperless Graphic Recorder



Signal Conditioners



Eurotherm

PID Controller

Eurotherm has several types of thermocontrol or PID Controller with single loop or multi loop types and has optional boards for IO modules, communication modules and meets high manufacturing standards and high accuracy



Single Loop



Multiloop



Eurotherm

Power Controller

Eurotherm SCR Power Controllers are suitable for multiple applications, whether the load is constant or variable resistance, inductive or transformer coupled, single or three phase. The standard product line has current ratings up to 1800A, but application specific units can range up to several thousand amps with external driver options.



SSR



Power
Controller



Power
Switch(SCR)



Eurotherm

Paperless Graphic Recorder

Paperless Graphic, Strip Chart and Circular Recorders

Ensure your precious process data is kept safe with our range of state-of-the-art recorders and data management software. Along with some of the best, proven recording and archiving strategies, Eurotherm recorders offer a wealth of functions including batch, audit trail, electronic signatures and remote viewing/operation – ensuring operational efficiency is optimised and enabling you to convert data into the information required to add value to a process.

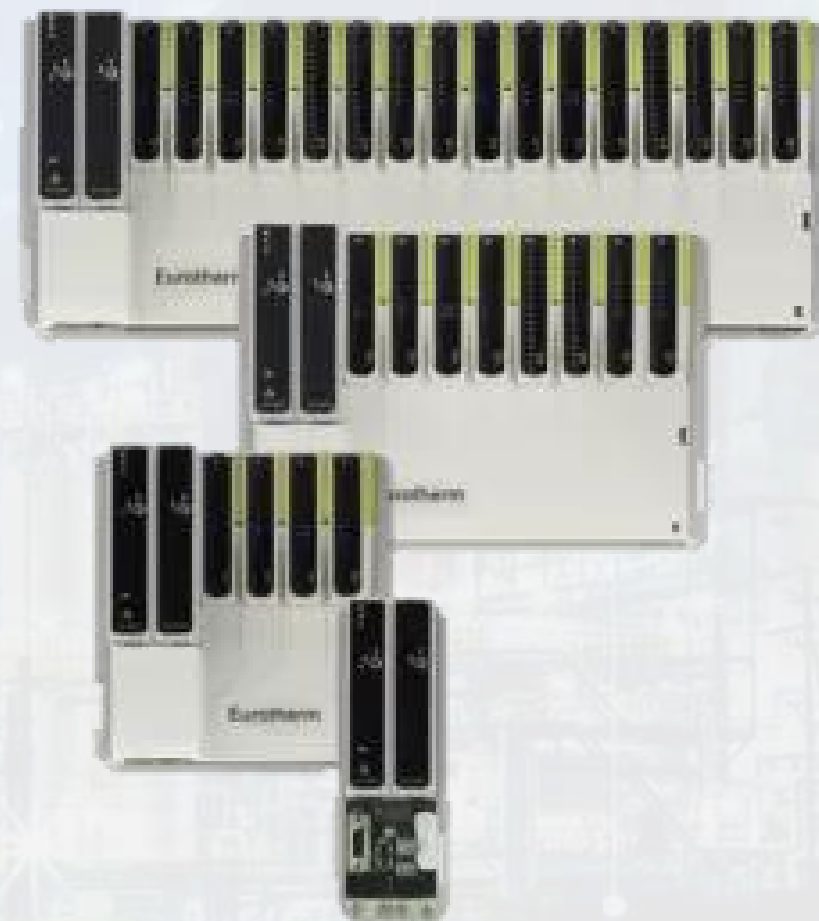
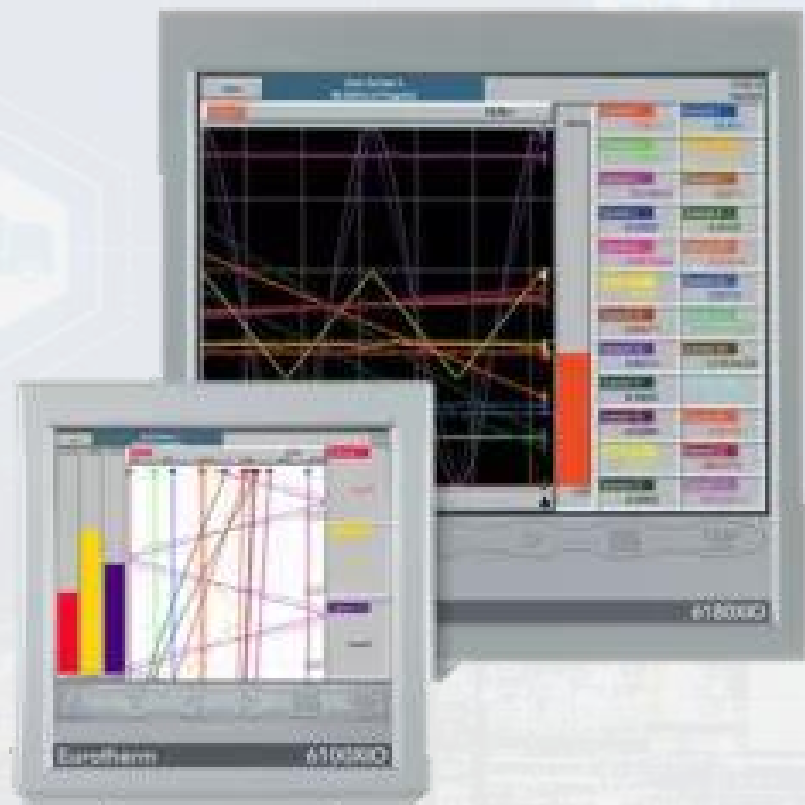



Eurotherm

Signal Conditioners

The complete range includes accessories and quality control products to ensure you get everything you need for a complete solution

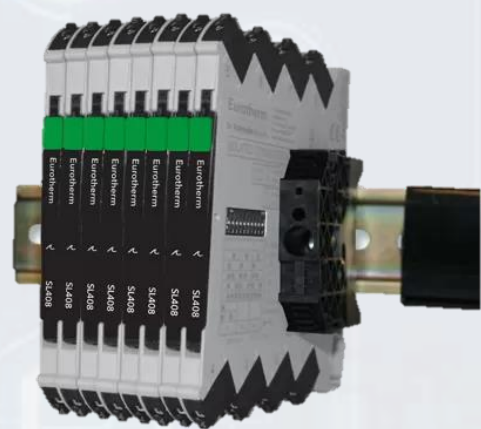

Omni Series



Ultra Slim Pack

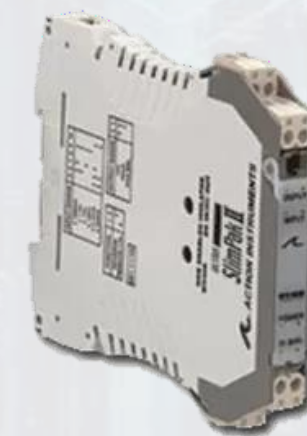

Ultra Slim Pack II



Our Client

SUNSTAR



Koito



EXCELITAS
TECHNOLOGIES

MAXXIS

AKR





*Thank
You*